

## 6.17 GM DIMENSIONAL DATA

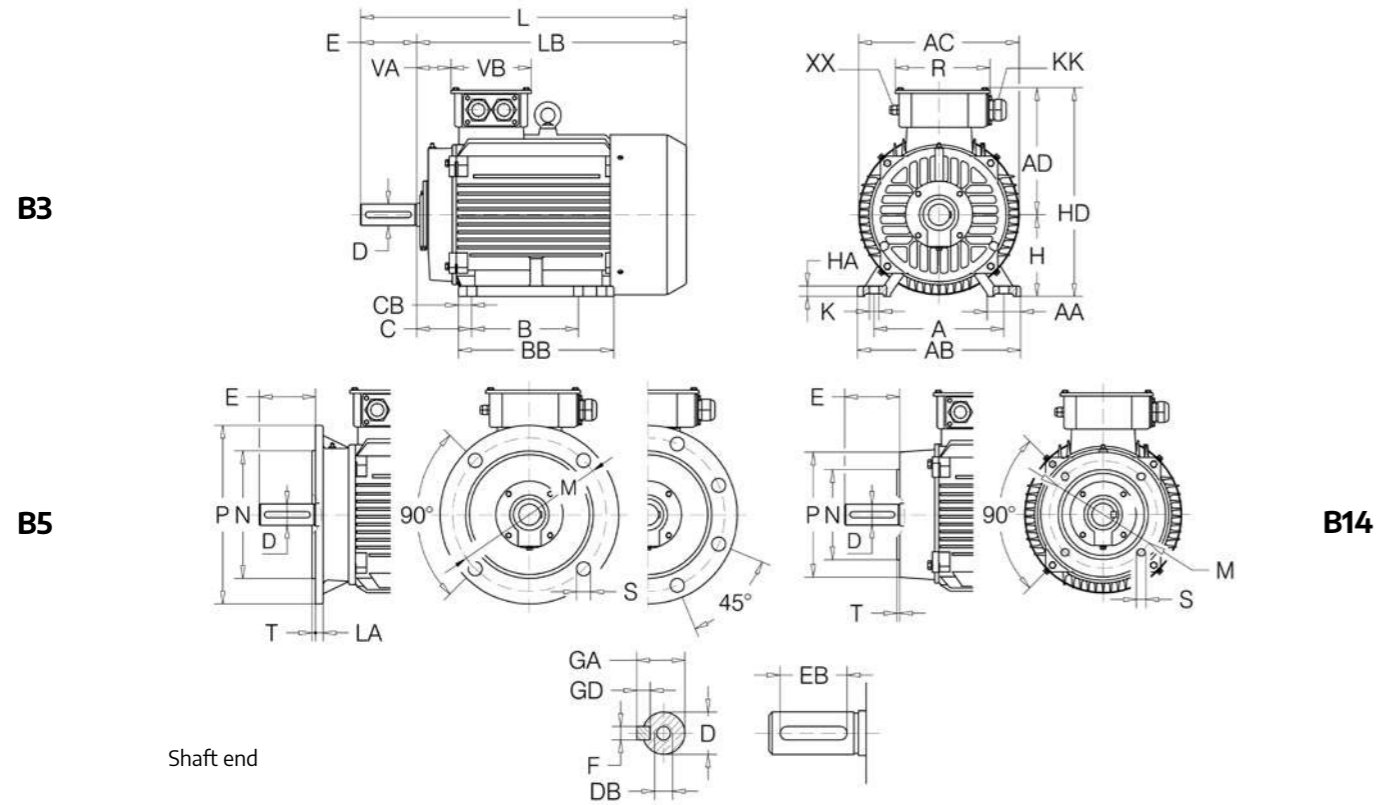

GM SERIES

Tab. 6.17.1

GM-GMD Motor	Main Overall Dimension							Feet							Flange								
	AC	AD	H	HD	LB	L	A	B	C	AB	BB	AA	CB	HA	K	IM	M	NJ6	P	LA	T	S	
160 M	2-4-6-8	314	251	160	411	498	608	254	210	108	320	260	65	26	20	15	B5	300	250	350	15	5	N°4 19
L		542	652	254	304	70	35	22	15	B14	215	180	250	--	4	N°4 M12							
180 M	2-4-6-8	355	267	180	447	578	688	279	241	121	350	311	70	35	22	15	B5	300	250	350	15	5	N°4 19
L		616	726	279	349	70	35	22	15	B5	300	250	350	15	5	N°4 19							
200 L	2-4-6-8	397	299	200	499	669	779	318	305	133	390	370	70	32	25	18	B5	350	300	400	17	5	N°4 19
225 S	2-4-6-8	446	322	225	547	684	824	356	286	149	432	370	75	46	28	19	B5	400	350	450	20	5	N°8 19
225 M	2-4-6-8	446	322	225	547	709	819	356	311	149	433	395	75	46	28	19	B5	400	350	450	20	5	N°8 19
250 M	2-4-6-8	485	358	250	608	770	910	406	349	168	486	445	80	55	30	24	B5	500	450	550	22	5	N°8 19
280 S	2-4-6-8	547	387	280	667	842	982	457	368	190	545	485	85	69	35	24	B5	500	450	550	22	5	N°8 19
M						893	1033					419											
315 S	2	620	527	315	842	1054	1194	508	406	216	630	570	120	84	45	28	B5	600	550	660	22	6	N°8 24
4-6-8	1224																						
315 M	2	620	527	315	842	1164	1304	508	457	216	630	680	120	84	45	28	B5	600	550	660	22	6	N°8 24
4-6-8	1334																						
315 L	2	620	527	315	842	1164	1304	508	508	216	630	680	120	84	45	28	B5	600	550	660	22	6	N°8 24
4-6-8	1334																						
355 M	2	698	642	355	997	1346	1486	610	560	254	730	750	120	68	52	28	B5	740	680	800	25	6	N°8 24
4-6-8	1556																						
355 L	2	698	642	355	997	1346	1486	610	630	254	730	750	120	68	52	28	B5	740	680	800	25	6	N°8 24
4-6-8	1556																						
355 X	2	770	765	355	1120	1710	1850	630	800	224	760	1140	135	88	52	35	B5	840	780	900	28	6	N°8 24
4-6-8	1920																						
400 M	2	860	680	400	1080	1770	1940	686	630	280	806	1090	120	57	45	35	B5	940	880	1000	25	6	N°8 28
4-6-8	1980																						
400 L	2	860	680	400	1080	1770	1940	686	710	280	806	1090	120	57	45	35	B5	940	880	1000	25	6	N°8 28
4-6-8	1980																						
450 L	2	960	820	450	1270	2050	2200	800	1000	250	990	1300	190	107	52	42	B5	940	880	1000	25	6	N°8 28
4-6-8	1990																						

## GM SERIES

Tab. 6.17.2

GM-GMD Motor	Shaft - End							Shaft - End						Terminal - Box							
	D	DB	E	GA	F	GD	EB	Flange-End			Drive End DE Non drive end NDE			Term.	Cable gland						
								Øi	Øe	H	Øi	Øe	H	N°-Ø	N°-KK	N°-XX	VA	VB	R		
160	2-4-6-8	42	M16	110	45	12	8	90	45	62	8/12	45	62	8/12	6-M6	2-M40x1,5	1-M16x1,5	67	158	185	
180	2-4-6-8	48	M16	110	51,5	14	9	100	55	75	8/12	55	75	8/12	6-M6	2-M40x1,5	1-M16x1,5	82	158	185	
200	2-4-6-8	55	M20	110	59	16	10	100	60	80	8/12	60	80	8/12	6-M8	2-M50x1,5	1-M16x1,5	92	187	224	
225	S	4-8	60	M20	140	64	18	11	125	65	90	10/12	65	90	10/12	6-M8	2-M50x1,5	1-M16x1,5	95	187	224
225	M	2	55	M20	110	59	16	10	100	60	80	8/12	60	80	8/12	6-M8	2-M50x1,5	1-M16x1,5	95	187	224
	4-6-8	140			64	18	11	125	65	90	10/12	65	90	10/12							
250	2	60	M20	140	64	18	11	125	65	90	10/12	65	90	10/12	6-M10	2-M63x1,5	1-M16x1,5	88	238	283	
	4-6-8			69	70				90	10/12	70	90	10/12								
280	2	65	M20	140	69	18	11	125	70	90	10/12	70	90	10/12	6-M10	2-M63x1,5	1-M16x1,5	96	238	283	
	4-6-8			79,5	20				12	125	85	110	10/12	85							110
315	2	65	M20	140	69	18	11	125	85	110	10/12	85	110	10/12	6-M12/16	2-M63x1,5	1-M16x1,5	117	280	320	
	4-6-8			80	170				85	22	14	140	95	120							10/12
355	2	75	M20	140	79,5	20	12	125	95	120	10/12	95	120	10/12	6-M20	2-M63x1,5	1-M16x1,5	117	328	380	
	4-6-8			100	M24				210	106	28	16	180	110							140
355	X	2	75	M20	170	79,5	20	12	140	95	120	10/12	95	120	10/12	6-M20	3-M63x1,5	1-M16x1,5	--	--	--
	4-6-8	100			M24	210				106	28	16	180	120	140						
400	M	2	80	M20	170	85	22	14	140	90	115	10/12	90	115	10/12	6-M24	3-M63x1,5	1-M16x1,5	--	--	--
	4-6-8	110			M24	210				116	28	16	180	130	150						
400	L	2	80	M20	170	85	22	14	140	90	115	10/12	90	115	10/12	6-M24	3-M63x1,5	1-M16x1,5	--	--	--
	4-6-8	110			M24	210				116	28	16	180	130	150						
450	L	2	95	M24	170	100	25	14	140	110	130	10/12	110	130	10/12	6-M24	3-M63x1,5	1-M16x1,5	--	--	--
	4-6-8	130			M24	210				137	32	18	180	140	160						